

# TS75

## SAFETY RELIEF VALVE

3/4"

UP TO 40 BAR 580 PSI

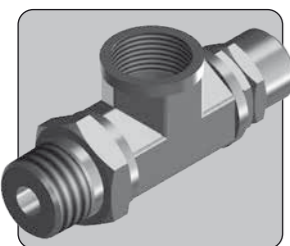

The TS75 is a safety relief valve with a threaded exhaust port for piping vented flow away from the valve. Designed with an elastomeric seat seal, the valve combines excellent leakage performance with a high discharge flow capacity from its pop-open characteristic.

The valve is approved as a safety accessory to category IV of the Pressure Equipment Directive, and is suitable for use in the most demanding liquid or gas applications.

- Approved to category IV of the Pressure Equipment Directive (2014/68/EU)
- Pop-open characteristic for maximum discharge capacity
- Available preset and internally adjustable
- Available with relieving gear to enable the manual release of pressure
- Wire locking and tagging available on request
- Virtually zero leakage at 90% of set pressure
- Reseat within the greater of 5 psi or 7.5% of set pressure when valve has opened and not popped
- Reseat within 50% of set pressure once popped
- Repeatability within the greater of 2 psi or ±3% of nominal set pressure

### Specifications

**BASIC MODEL NUMBER**

**TS75**

**SYMBOL**

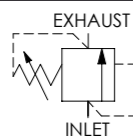

**MAX WORKING PRESSURE**

40 bar  
(580 psi)

**MAX OUTLET PORT PRESSURE**

10 bar  
(145 psi)  
*Note: Any outlet port pressure is directly additive to the set pressure*

**ORIFICE SIZE**

Ø9.8mm  
(Ø0.386")

**FLUID**

Liquids and Gases  
*See materials section*

**TEMPERATURE RANGE**

*See Product Selector opposite and Technical Data section*

**PORT SIZE**

3/4"

**WEIGHT**

0.4 kg  
(0.9 lb)

*Specifications may change without notice*

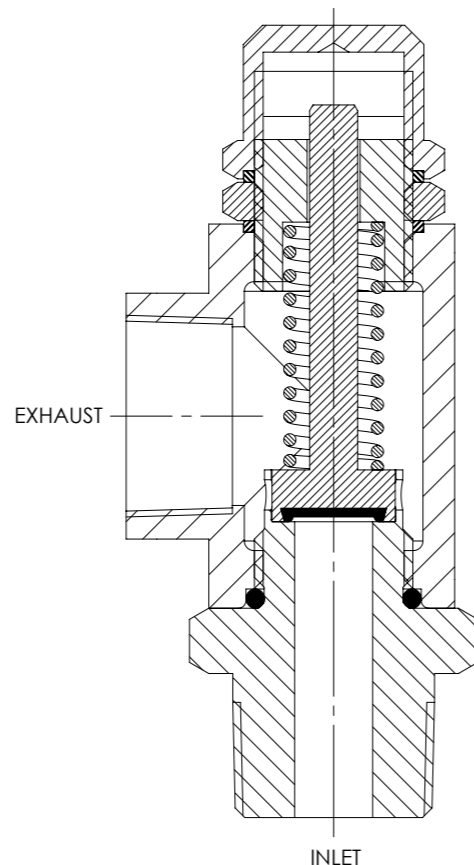

### Materials

Externally Exposed Parts: 316 stainless steel and acetal.  
Internally Wetted Parts: 316 and 302 stainless steel, and acetal.

The standard valve is designed for use with air, nitrogen, sweet natural gas, mineral oil, water glycols and plain water, and may also be used with a wide variety of media compatible with the materials of construction. Other material options are available, contact us for advice. Note that use with water above 100°C is not recommended.

⚠ The standard valve has Viton® seals. Further seal options are available via the Product Selector. Compatibility with the working fluid at the operating temperature must be considered.

### Typical Performance

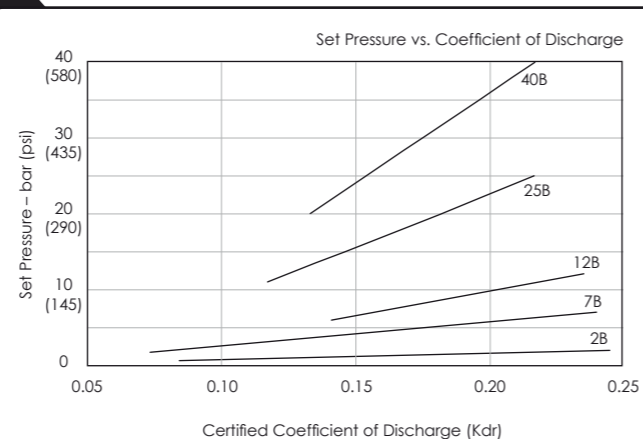

The Kdr value may be used to calculate discharge capacity in accordance with ISO 4126. We recommend contacting us with system details to confirm suitability.

### Installation Diagram

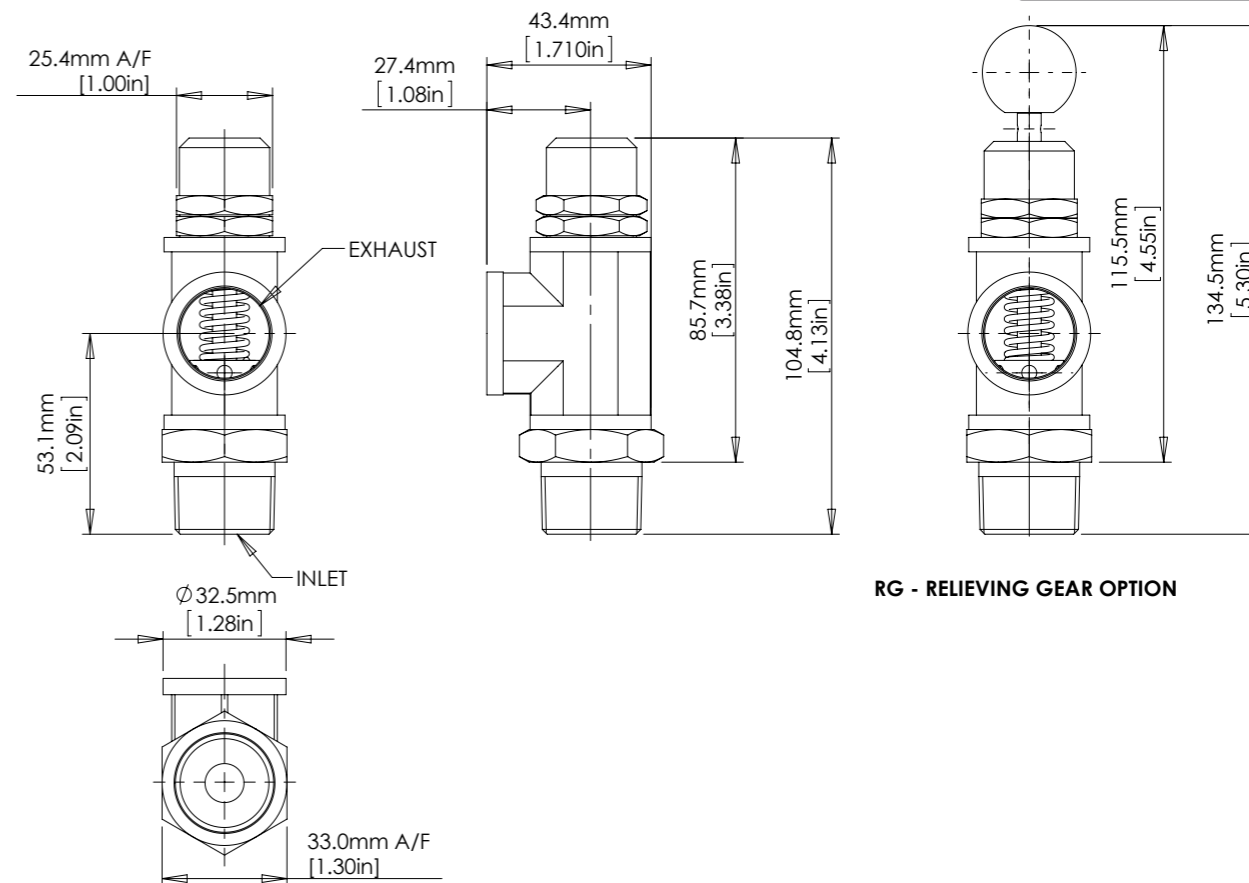

RG - RELIEVING GEAR OPTION

### Product Selector

TS75 P - RG - NBR - 2B

VALVE TYPE	PORTING OPTIONS	VALVE OPTIONS	SEAL OPTIONS	SET PRESSURE RANGE
TS75	<p><b>P</b> 3/4" BSPP male inlet 3/4" BSPP female exhaust</p> <p><b>N</b> 3/4" NPT male inlet 3/4" NPT female exhaust</p>	<p><b>RG</b> Relieving gear</p> <p><i>Leave blank if not required</i></p> <p><i>This option is not recommended with the 2B spring option</i></p> <p>⚠ Exposure to high and low fluid temperatures will influence handle temperature. Operator safety must be considered</p>	<p><b>NBR</b> Nitrile seals -30°C to +105°C</p> <p><b>EP</b> EPDM seals -45°C to +150°C</p> <p><b>KLZ</b> Kalrez® seals -25°C to +200°C</p> <p><b>HNBR</b> Hydrogenated Nitrile seals -20°C to +150°C</p> <p><i>Further seal options are available on request</i></p>	<p><b>2B</b> 0.7 - 2 bar (10 - 29 psi)</p> <p><b>7B</b> 2 - 7 bar (29 - 102 psi)</p> <p><b>12B</b> 6 - 12 bar (87 - 174 psi)</p> <p><b>25B</b> 11 - 25 bar (160 - 363 psi)</p> <p><b>40B</b> 20 - 40 bar (290 - 580 psi)</p> <p><i>Advise us of set pressure if factory pre-setting is required</i></p>

Repair and seal kits are available on request

For a seal kit add SK at the end of the model code and for a repair kit add RK



CATALOGUE ALSO AVAILABLE ON CD  
VISIT OUR WEBSITE FOR A FULL ONLINE SEARCH FACILITY  
[www.bisvalves.co.uk](http://www.bisvalves.co.uk)



**BIS VALVES**  
The Specifier's Catalogue Page ???

SOLENOID  
FLOW CONTROL  
3 PORT DIRECTIONAL CONTROL  
4 PORT DIRECTIONAL CONTROL  
CHECK AND SHUTTLE  
PILOT OPERATED CHECK  
RELIEF  
EXCESS FLOW  
FILTERS  
PRESSURE SENSING  
PUMPS  
ACTUATORS  
TECHNICAL DATA